

EXALT 48 SHOWER DOOR

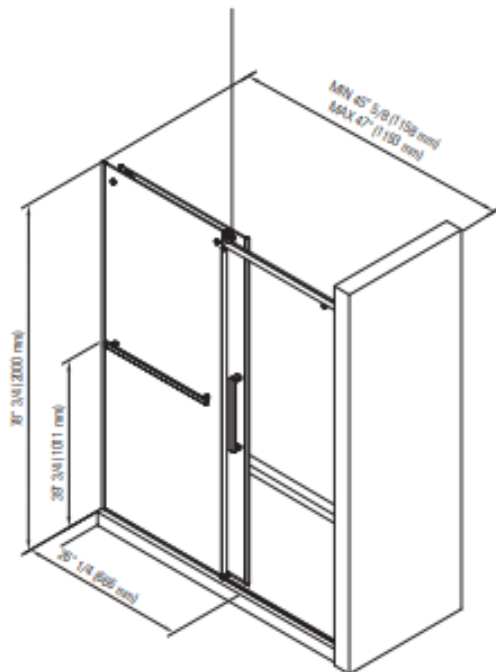

* Produits Neptune applies a cutting edge protective covering, which repels water and dirt for easy cleaning and increases the lifespan of your shower doors.

PRODUCT DESCRIPTION:

Contemporary style
Fixed panel and sliding door panel
8 mm glass (1/3")
Right or left opening
Offered in chrome/clear or black/clear

24 hrs

BOXES SIZE:

82" x 30" x 3"

WEIGHT:

126 lbs



Certification ECORESPONSIBLE
First manufacturer of bathroom products in North America to be certified ecoresponsible.



Produits Neptune

6835, Picard street, Saint-Hyacinthe (Quebec) J2S 1H3
Phone: (450) 773-7058 - produitsneptune.com

REV: 08-19

EXALT 60 SHOWER DOOR

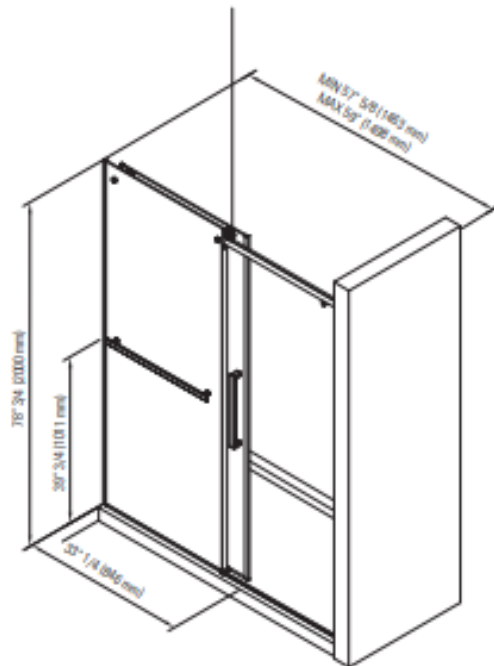

* Produits Neptune applies a cutting-edge protective covering, which repels water and dirt for easy cleaning and increases the lifespan of your shower doors.

PRODUCT DESCRIPTION:

Contemporary style
Fixed panel and sliding door panel
8 mm glass (1/3")
Right or left opening
Offered in chrome/clear or black/clear

24 hrs

BOXES SIZE:

82" x 35" x 3"

WEIGHT:

158 lbs



Certification ECORESPONSIBLE
First manufacturer of bathroom products in North America to be certified ecoresponsible.



Produits Neptune

6835, Picard street, Saint-Hyacinthe (Quebec) J2S 1H3
Phone: (450) 773-7058 - produitsneptune.com

REV: 08-19

EXALT 3648 SHOWER DOOR

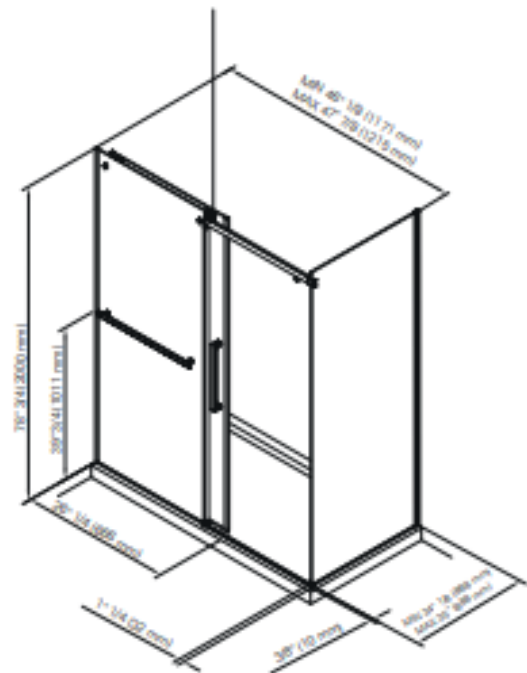

* Produits Neptune applies a cutting-edge protective covering, which repels water and dirt for easy cleaning and increases the lifespan of your shower doors.

PRODUCT DESCRIPTION:

Contemporary style
Fixed panel, sliding door panel
and return panel
8 mm glass (1/3")
Right or left corner installation
Offered in chrome/clear or black/clear

24 hrs

BOXES SIZE:

82" x 38" x 3"

WEIGHT:

210 lbs



Certification ECORESPONSIBLE
First manufacturer of bathroom products in North America to be certified ecoresponsible.



Produits Neptune

6835, Picard street, Saint-Hyacinthe (Québec) J2S 1H3
Phone: (450) 773-7058 - produitsneptune.com

REV: 08-19

EXALT 3260 SHOWER DOOR

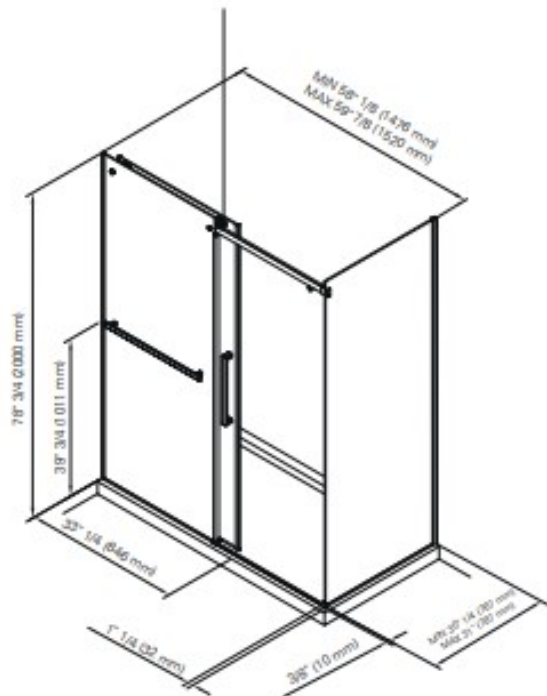

PRODUCT DESCRIPTION:

Contemporary style
Fixed panel, sliding door panel
and return panel
8 mm glass (1/3")
Right or left corner installation
Offered in chrome/clear or black/clear

24 hrs

BOXES SIZE:

82" x 35" x 3"

WEIGHT:

234 lbs

* Produits Neptune applies a cutting edge protective covering, which repels water and dirt for easy cleaning and increases the lifespan of your shower doors.



Certification Ecoresponsible
First manufacturer of bathroom products in North America to be certified ecoresponsible.



Produits Neptune

6835, Picard street, Saint-Hyacinthe (Quebec) J2S 1H3
Phone: (450) 773-7058 - produitsneptune.com

REV: 08-19

EXALT 3660 SHOWER DOOR

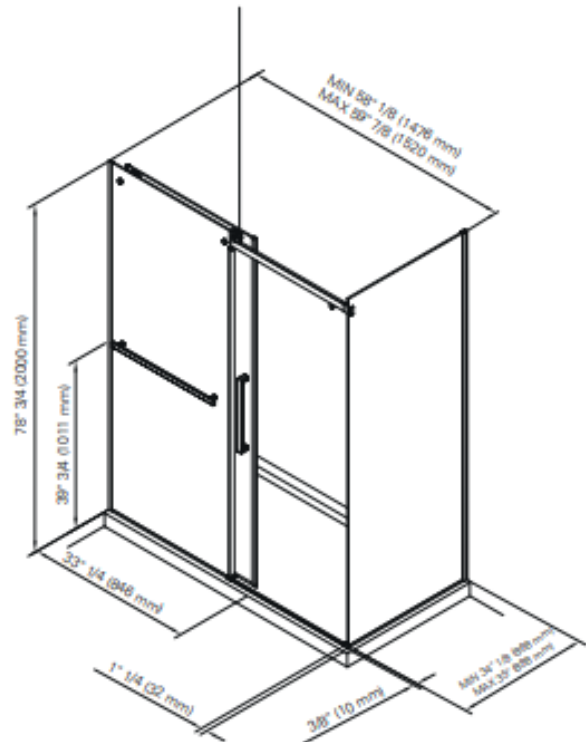

PRODUCT DESCRIPTION:

Contemporary style
Fixed panel, sliding door panel
and return panel
8 mm glass (1/3")
Right or left corner installation
Offered in chrome/clear or black/clear

24 hrs

BOXES SIZE:

82" x 38" x 3"

WEIGHT:

242 lbs

* Produits Neptune applies a cutting-edge protective covering, which repels water and dirt for easy cleaning and increases the lifespan of your shower doors.



Certification Ecoresponsible
First manufacturer of bathroom products in North America to be certified ecoresponsible.



Produits Neptune

6835, Picard street, Saint-Hyacinthe (Quebec) J2S 1H3
Phone: (450) 773-7058 - produitsneptune.com

REV: 08-19