

New Town 6032 IFS Acrylic Alcove Bathtub

Model number:

105456-000-001-001

Dimensions: 59.75" x 32" x 20.5"

Installation: Alcove

Material: Acrylic

Standard Features:

- Alcove bathtub
- Acrylic surface resistant to stains
- Available in white, bone or biscuit color to complement any bathroom decor
- Available in left-hand and right-hand drain configurations to fit your specific bathroom layout
- Integrated flat skirt and tiling flange
- Bride de carrelage intégrée pour une meilleure protection contre les fuites et une installation facile des murs de douche

Product characteristics:

- 1-Piece Tub
- Integrated Tiling Flange and Skirt
- Integrated Armrest

Systems:

- 10 microjets
- Aerosens



Standard Colors:



White



Bone



Biscuit

Certifications

MAAX products adhere to one or more of the following certifications:



MAAX

New Town 6032 IFS Acrylic Alcove Bathtub

Model number:

105456-000-001-001

Dimensions: 59.75" x 32" x 20.5"

Installation: Alcove

Material: Acrylic

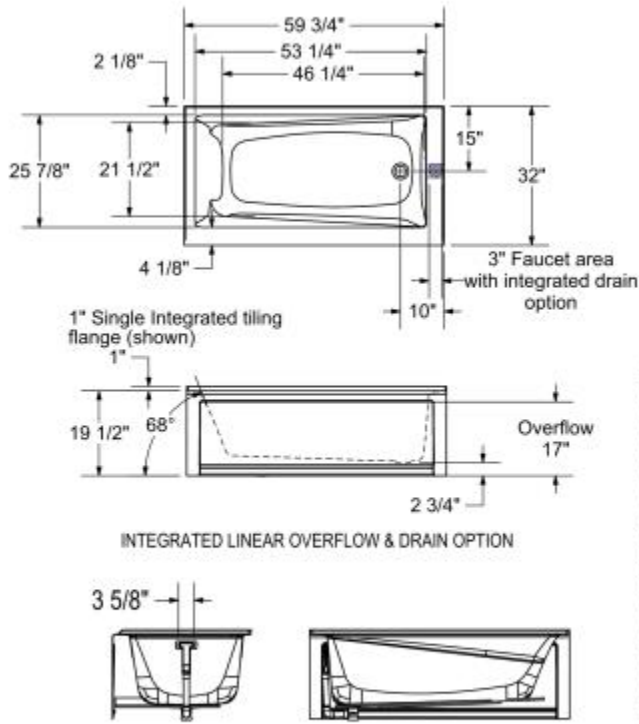

WITHOUT SYSTEM



WITH SYSTEM

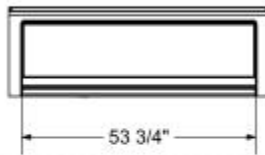

MICROJETS SYSTEM

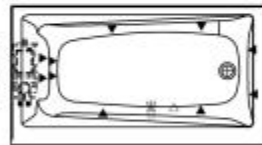

AIR SYSTEM

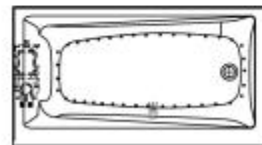

- (▲) : Indicates whirlpool jets positioning
- (△) : Indicates suction positioning
- (●) : Indicates airjets positioning
- (☒) : Indicates chromatherapy light positioning

Wood support design may vary.
Single Integrated tiling flange: 1" height x 1/4" thickness (shown)

All dimensions are approximate.
Structure measurement must be verified against the unit to ensure proper fit.

Dimensions

59 3/4 x 32 x 20 1/2 In.
(1518 x 813 x 521 mm)

Water Capacity

46 gallons - 174 liters

Weight

78 lbs - 35 kg

Bathing Well

47 In. x 20 3/4 In.
(1194 mm x 524 mm)

Deep Sump Height

16.25 In. - 413 mm

Deck Width

3.75 In. - 95 mm

Drain location:

Left

Right

Project: _____

Contractor: _____

Representative: _____

Date: _____

Tel: _____

Notes: _____

MAAX